



# LOUISIANA NATIONAL GUARD

PROTECT WHAT MATTERS<sup>SM</sup>

## EQUAL OPPORTUNITY





## Outline

- Roles and responsibilities
- Training requirements
- Command climate surveys
- Complaint procedures
- Diversity initiatives
- Policy letters
- Q&A



## **Roles and Responsibilities**

- Commanders
- SEEM
- EO Advisors
- EO Leaders



## Staffing

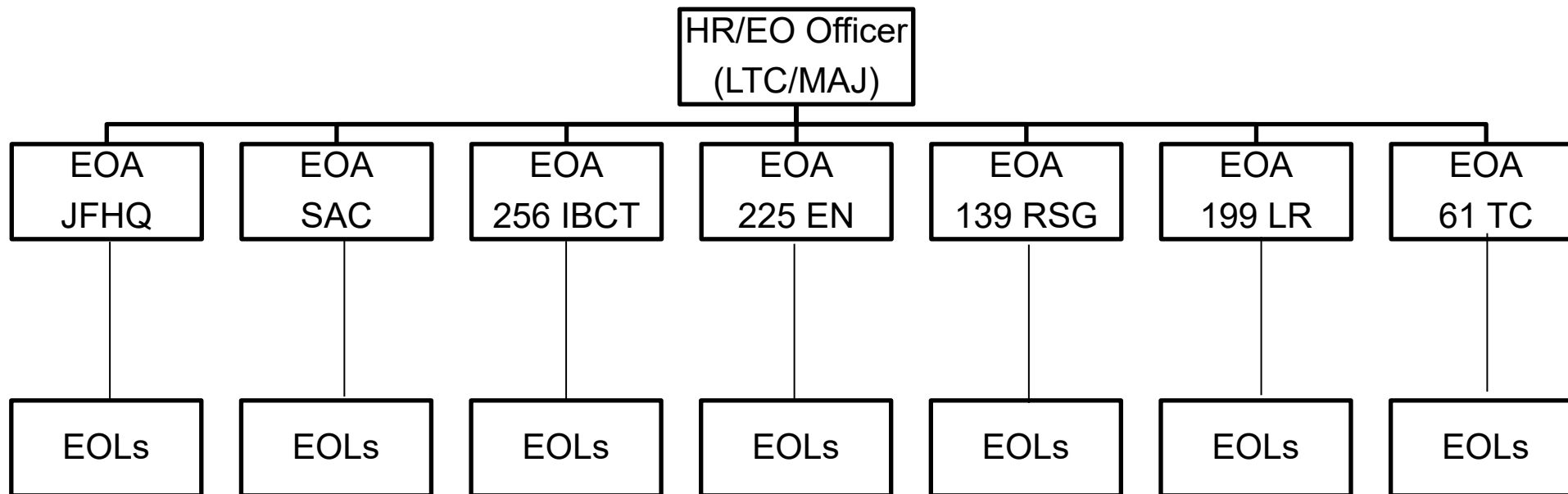



## EO Advisor Staffing

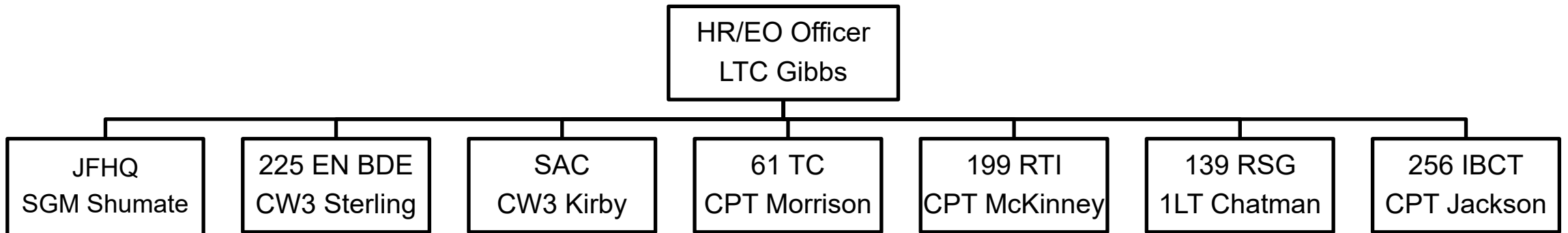



## EO Training Requirements

- Once per year as a minimum
- Training must be input into DTMS
- Should be conducted following an “incident” or as a result of climate survey results.



## Command Climate Surveys

- Anonymous
- Conducted within 120 days after a change of command and annually thereafter.
- System requires a minimum of 16 participants to generate report.
- Can be done on a smart phone.



## EO Complaint Procedures

- Formal EO complaints will be processed by the SEEM or EO Advisors.
- EO Leaders (EOLs) do NOT process formal EO complaints.
- TAG withholds authority to investigate allegations of sexual harassment, racial discrimination, gender discrimination, and sexual orientation discrimination.





## Diversity Initiatives

- Create an inclusive environment
- Conduct ethnic observances



## POC

Mr. Philip Cancienne

504-278-8152 (Office)

504-258-4943 (Cell)

[philip.m.cancienne.mil@army.mil](mailto:philip.m.cancienne.mil@army.mil)



PROTECT WHAT MATTERS<sup>SM</sup>

**Questions?**